

1. GENERAL DESCRIPTION

Coils type 455GD are device suitable to be installed in zone 1 / zone 21 with type of protection Ex db IIC / Ex tb IIIC and Ex db I for mine, in accordance with:

- IEC 60079-0: 2011 Equipment - General requirements
- IEC 60079-1: 2014 Equipment protection by flameproof enclosures "d"
- IEC 60079-31 2013 Equipment dust ignition protection by enclosure "t"
- EN 60079-0: 2012/A11: 2013 Equipment - General requirements
- EN 60079-1: 2014 Equipment protection by flameproof enclosures "d"
- EN 60079-31 2014 Equipment dust ignition protection by enclosure "t"

Model identification

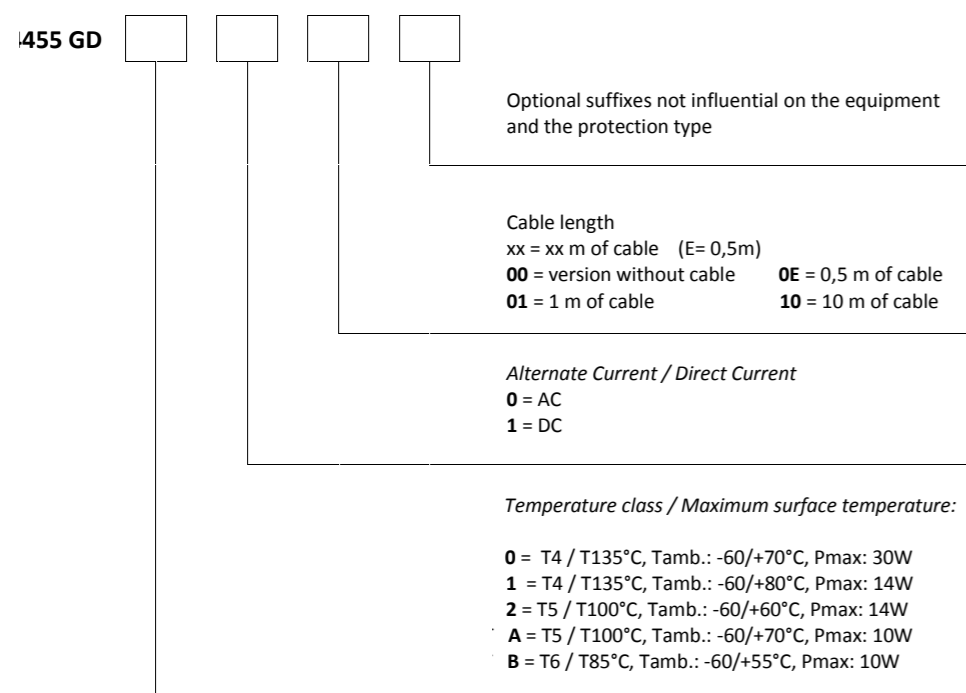

2. TECHNICAL CHARACTERISTICS

Rated voltage: 6 ÷ 240V_{DC} / 6 ÷ 240 V_{AC} - 50/60 Hz

The temperature class and the maximum surface temperature depends on the solenoid power and ambient temperature

Temperature class	Maximum surface temperature	Ambient temperature	Rated Voltage	Max. Power
T4	T135°C	-60°C ÷ +70°C	6 ÷ 240 V _{AC/DC}	30 W
T4	T135°C	-60°C ÷ +80°C	6 ÷ 240 V _{AC/DC}	14 W
T5	T100°C	-60°C ÷ +60°C	6 ÷ 240 V _{AC/DC}	14 W
T5	T100°C	-60°C ÷ +70°C	6 ÷ 240 V _{AC/DC}	10 W
T6	T85°C	-60°C ÷ +55°C	6 ÷ 240 V _{AC/DC}	10 W

T fluid max: ≤ maximum ambient temperature

Cable: 3x1,5mm² suitable for maximum temperature = 105°C (minimum length = 1m)

Cable not mounted on 455GD...00 version

3. MARKING

ATAM S.p.A
Type : 455GD

ATEX Directive:

CE 0722 Ex II 2 GD / I M2

Type of protection (ATEX/IECEx)

Ex db IIC T6, T5, T4 Gb
Ex tb IIIC T85°C, T100°C, T135°C Db IP66/67
Ex db I Mb

Each models is provided by specific marking depending the electromagnets power and ambient temperature.

ATEX Directive

0722 = Notified Body identification number for quality production survey (CESI)
II / I = group II and group I
2 GD = category 2 GD, equipment suitable for zone 1 (gas) and zone 21 (dust)
M2 = category M2, equipment for mine, de-energized when explosive atmosphere present

Type of protection (ATEX/IECEx)

Ex db IIC = type of protections for gas group IIC
T6, T5, T4 = temperature class for gas
Gb = EPL (Gas)
Ex tb IIIC = type of protection for dust group IIIC
T85°C, T100°C, T135°C = maximum surface temperature for dust
Db = EPL (Dust)
Ex db I = type of protection for group I
Mb = EPL (Mine)
IP66/67 = Degree of protection (IP)

Relation between hazardous areas, categories and EPL

Hazardous area		ATEX categories	EPL
Gas, vapour or fog	Zone 0	1G	Ga
Gas, vapour or fog	Zone 1	2G or 1G	Gb or Ga
Gas, vapour or fog	Zone 2	3G, 2G or 1G	Gc, Gb or Ga
Dust	Zone 20	1D	Da
Dust	Zone 21	2D or 1D	Db or Da
Dust	Zone 22	3D, 2D or 1D	Dc, Db or Da
Mine	-	M2	Mb or Ma

4. SAFETY INSTRUCTIONS FOR INSTALLATION IN HAZARDOUS AREAS

Coils type 455GD... shall be installed and maintained according to the applicable standards regarding electrical installations in hazardous area (for example: IEC/EN 60079-14 and IEC/EN 60079-17 or other national standard).

Before installing, carefully read the instruction manual.

This apparatus must be installed and put into operation in accordance with the provisions and regulations. Shall not be liable for damage caused by non-observance of the instructions and inappropriate use.

Bodies of electromagnets type 455GD... are provided by an external ground connection terminal located onto the body. Such a terminal must be connected to the earth line of system with a suitable cable.

An additional ground wire, connected internally to the body of coils, is incorporated to the cable of solenoids. It is a green-yellow cable with section of 1,5 mm². The cable used shall be suitable for temperature = 105°C.

It is forbidden any technical modification.

In zones with presence of combustible dusts, it is necessary to periodically clean the surface of the coil, limiting the depth of the layer to less than 5 mm.

Any repair activity of the ex-proof coils isn't admitted. In case of damage any ex-proof coil must be replaced with a new one of the same type.

Wiring:

Wiring should be carried out with main power turned off.

Use always the proper connector already pre-assembled inside the coil according to the instructions listed below.

Step_1

Remove carefully main flange by unscrewing 2 screws.

During this operation take care of preventing any damage to the gasket.

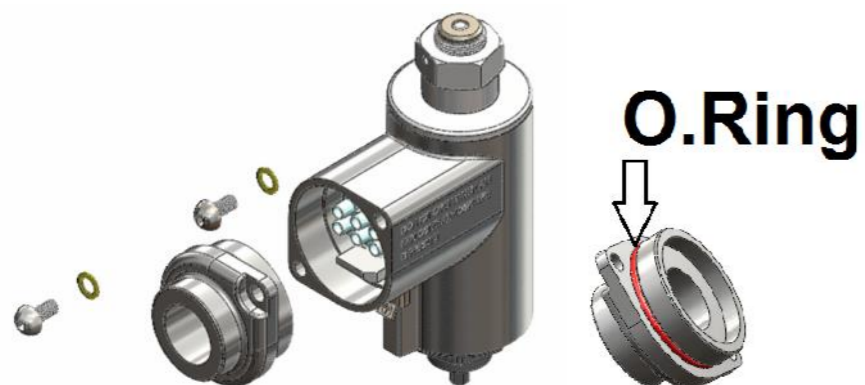

Step_2

Use proper cable gland ATEX/IECEx certified with type of protection Ex d IIC/ Ex d I/Ex tb IIIC, thread 1/2" NPT, min. IP66 / IP67

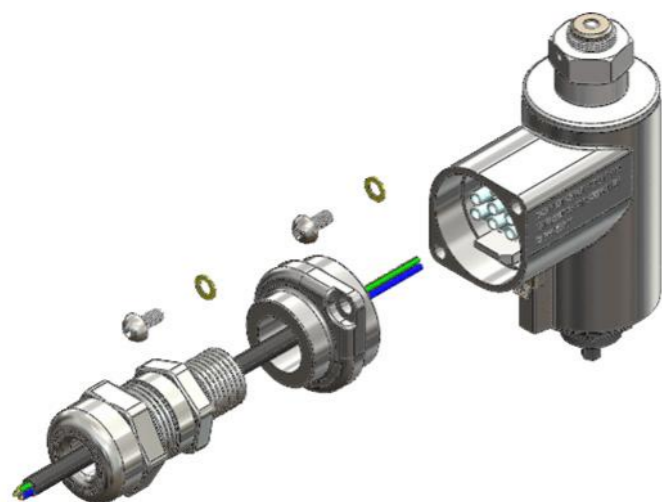

Step_3

Remove the connector and then proceed with main wiring to the proper positions as indicated below according to voltage type (AC or DC).

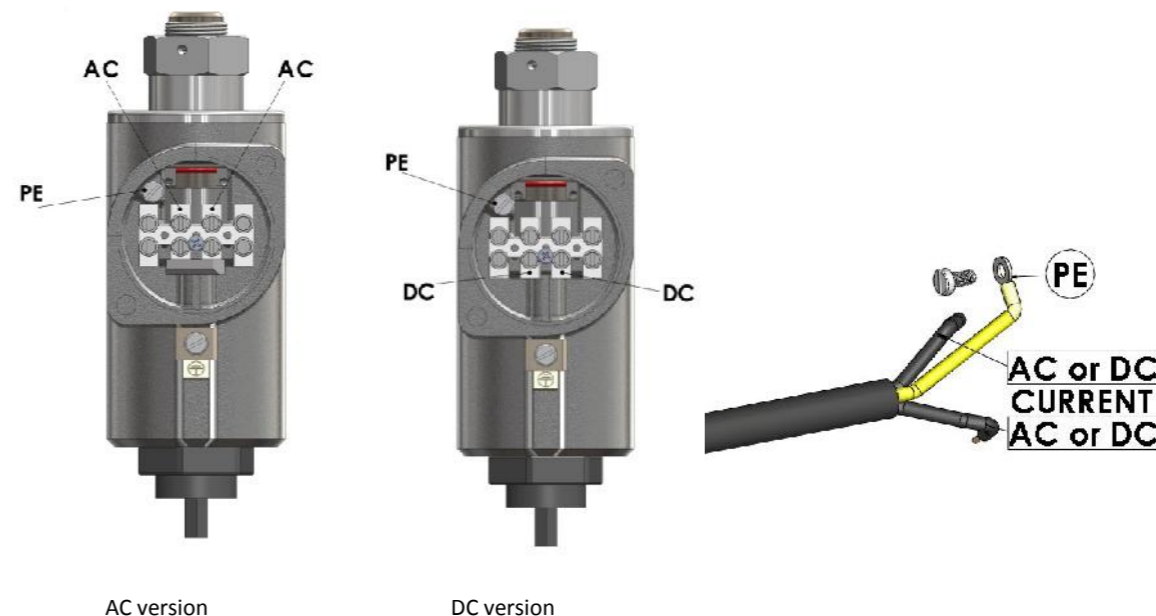

Step_4

Re-assemble the flange carefully, taking into account to prevent any damage to the gasket. Respect max fixing torque as indicated below

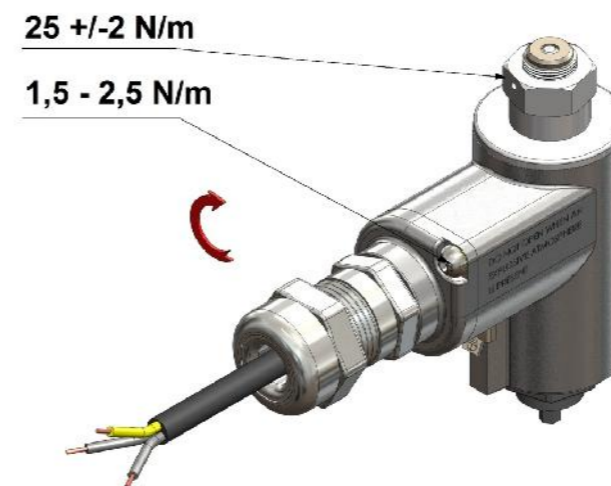

Notes:

- The values used for the maximum gap of construction of flameproof joints are less than the values specified in the tables of the IEC/EN 60079-1 standard.
- The width of the different flameproof joints is superior to the values specified in tables of the IEC/EN 60079-1 standard.
- Actuator fixing torque: 25±2 Nm

Warning label: DO NOT OPEN WHEN AN EXPLOSIVE ATMOSPHERE IS PRESENT.
T cable : 105°C.